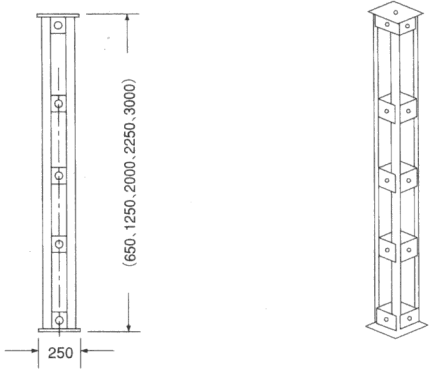
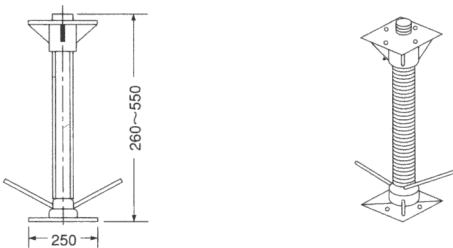
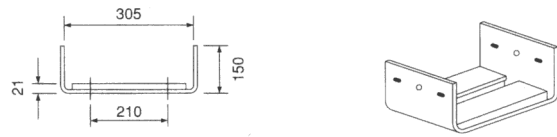
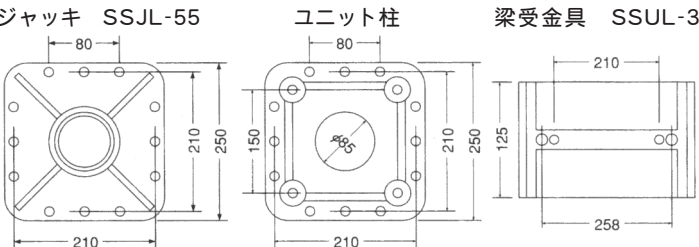

四角支柱

軽量型

| 符 号 | 形 状・寸 法 | 備 考 |
|--|---|---|
| ユニット柱 SSL-300 SSL-225 SSL-200 SSL-125 SSL- 65 |  | 各寸法に合せ、ユニット柱、 ジャッキを組合せ使用する |
| ジャッキ SSJK-55 |  | 調整範囲：260～550 |
| 梁受金具 SSUL-31 |  | ジャッキ頭部にセットする |
| 受 板 台 板 | ジャッキ SSJL-55 ユニット柱 梁受金具 SSUL-31  | 板厚：8 ボルト穴直径：18 使用ボルトナット：M16×40 (販売品) |

規 格

| 項目 | 符号 | SSL-300 | SSL-225 | SSL-200 | SSL-125 | SSL-65 | SSJL-55 | SSUL-31 |
|---------|----|---|---------|---------|---------|--------|---------|---------|
| 使用高さ | | 3000 | 2250 | 2000 | 1250 | 650 | 260～550 | |
| 重量 (kg) | | 37.5 | 33.5 | 31.1 | 22.1 | 14.1 | 20.8 | 7.0 |
| 支柱材 | | SS G3444 (一般構造用炭素鋼鋼管) STK-500、φ42.7×2.4 | | | | | | |
| 台板・受板 | | SS G3106 (一般構造用圧延鋼材) SS-34以上 | | | | | | |

断面性能表

| 断面積 (A) | 断面二次モーメント (I) | 断面係数 (Z) | 断面二次半径 (i) |
|-----------------------|----------------------|---------------------|------------|
| 12.156cm ² | 708.5cm ⁴ | 94.5cm ³ | 7.63cm |

四角支柱の組合せ表 (軽量型)

| ユニット柱の組合せ | | | | | | | ユニット柱とジャッキSSJ-58(SSJ-55)の組合せ | | | |
|--------------------|---------------------|---------------------|---------------------|---------------------|---------|--------|------------------------------------|--------|-------------------------------|--------|
| SSH (SSL) 65 | SSH (SSL) 125 | SSH (SSL) 200 | SSH (SSL) 225 | SSH (SSL) 300 | 高さ L | 重量(kg) | L+SSJ+SSU 高さH L+SSJ(280~580) | 重量(kg) | L+2×SSJ+SSU 高さH L+2×SSJ | 重量(kg) |
| | | | | | | 軽量型 | | 軽量型 | | 軽量型 |
| 1 | | | | | 650 | 14.1 | 951~1,251 | 41.9 | 1,231~1,831 | 62.7 |
| | 1 | | | | 1,250 | 22.1 | 1,551~1,851 | 49.9 | 1,831~2,431 | 70.7 |
| 2 | | | | | 1,300 | 28.2 | 1,601~1,901 | 56.0 | 1,881~2,481 | 76.8 |
| 1 | 1 | | | | 1,900 | 36.2 | 2,201~2,501 | 64.0 | 2,481~3,081 | 84.8 |
| | | 1 | | | 2,000 | 31.1 | 2,301~2,601 | 58.9 | 2,581~3,181 | 79.7 |
| | | | 1 | | 2,250 | 33.5 | 2,551~2,851 | 61.3 | 2,831~3,431 | 82.1 |
| | 2 | | | | 2,500 | 44.2 | 2,801~3,101 | 72.0 | 3,081~3,681 | 92.8 |
| 1 | | 1 | | | 2,650 | 45.2 | 2,951~3,251 | 73.0 | 3,231~3,831 | 93.8 |
| 1 | | | 1 | | 2,900 | 47.6 | 3,201~3,501 | 75.4 | 3,481~4,081 | 96.2 |
| | | | | 1 | 3,000 | 37.5 | 3,301~3,601 | 65.3 | 3,581~4,181 | 86.1 |
| | 1 | 1 | | | 3,250 | 53.2 | 3,501~3,851 | 81.0 | 3,831~4,431 | 101.8 |
| | 1 | | 1 | | 3,500 | 55.6 | 3,801~4,101 | 83.4 | 4,081~4,681 | 104.2 |
| | 3 | | | | 3,750 | 66.3 | 4,051~4,351 | 94.1 | 4,331~4,931 | 114.9 |
| | | 2 | | | 4,000 | 62.2 | 4,301~4,601 | 90.0 | 4,581~5,181 | 110.8 |
| | | 1 | 1 | | 4,250 | 64.6 | 4,551~4,851 | 92.4 | 4,831~5,431 | 113.2 |
| | | | 2 | | 4,500 | 67.0 | 4,801~5,101 | 94.8 | 5,081~5,681 | 115.6 |
| | 2 | | 1 | | 4,750 | 77.7 | 5,051~5,251 | 105.5 | 5,331~5,931 | 126.3 |
| | | 1 | | 1 | 5,000 | 68.6 | 5,301~5,601 | 96.4 | 5,581~6,181 | 117.2 |
| | | | 1 | 1 | 5,250 | 71.0 | 5,551~5,851 | 98.8 | 5,831~6,431 | 119.6 |
| | 1 | 1 | 1 | | 5,500 | 86.7 | 5,801~6,101 | 114.0 | 6,081~6,681 | 135.3 |
| | 1 | | 2 | | 5,750 | 89.1 | 6,051~6,351 | 116.9 | 6,331~6,931 | 137.7 |
| | | | | 2 | 6,000 | 75.0 | 6,301~6,601 | 102.8 | 6,581~7,181 | 123.6 |
| | | 2 | 1 | | 6,250 | 95.7 | 6,551~6,851 | 123.5 | 6,831~7,431 | 144.3 |
| | | 1 | 2 | | 6,500 | 98.1 | 6,801~7,101 | 125.9 | 7,081~7,681 | 146.7 |
| | | | 3 | | 6,750 | 100.5 | 7,051~7,351 | 128.3 | 7,331~7,931 | 149.1 |
| | | 2 | | 1 | 7,000 | 99.7 | 7,301~7,601 | 127.5 | 7,581~8,181 | 148.3 |
| | | 1 | 1 | 1 | 7,250 | 102.1 | 7,551~7,851 | 129.9 | 7,831~8,431 | 150.7 |
| | | | 2 | 1 | 7,500 | 104.5 | 7,801~7,101 | 132.3 | 8,081~8,681 | 153.1 |
| | 1 | 1 | 2 | | 7,750 | 120.2 | 8,051~8,351 | 148.0 | 8,331~8,931 | 168.8 |
| | | 1 | | 2 | 8,000 | 106.1 | 8,301~8,601 | 133.9 | 8,581~9,181 | 154.7 |
| | | | 1 | 2 | 8,250 | 108.5 | 8,551~8,851 | 136.3 | 8,831~9,431 | 157.1 |
| | | 2 | 2 | | 8,500 | 129.2 | 8,801~9,101 | 157.0 | 9,081~9,681 | 177.8 |
| | | 1 | 3 | | 8,750 | 131.6 | 9,051~9,351 | 159.4 | 9,331~9,931 | 180.2 |
| | | | | 3 | 9,000 | 112.5 | 9,301~9,601 | 140.3 | 9,581~10,181 | 161.1 |
| | | 2 | 1 | 1 | 9,250 | 133.2 | 9,551~9,851 | 161.0 | 9,831~10,431 | 181.8 |
| | | 1 | 2 | 1 | 9,500 | 135.6 | 9,801~10,101 | 163.4 | 10,081~10,681 | 184.2 |
| | | | 3 | 1 | 9,750 | 138.0 | 10,051~10,351 | 165.8 | 10,331~10,931 | 186.6 |
| | | 2 | | 2 | 10,000 | 137.2 | 10,301~10,601 | 165.0 | 10,581~11,181 | 185.8 |
| | 1 | | | 3 | 10,250 | 134.6 | 10,551~10,851 | 162.4 | 10,831~11,431 | 183.2 |
| | | | 2 | 2 | 10,500 | 142.0 | 10,801~11,101 | 169.8 | 10,081~11,681 | 190.6 |

(注) 1.ユニット柱とジャッキの組合せ時の重量には梁受金具 SSJ: 11.2kg、SSUL-31: 7kgを含む。
2.表面処理: 熔融亜鉛メッキ

※ 軽量型寸法は上記表より差引いてください。

MIN MAX
L+SSJLの時 -20 -30
L+SSJL+SSJLの時 -40 -60